



**FITTING INSTRUCTIONS FOR LP0360 TAIL TIDY**



**This kit contains the items pictured and labelled over page.  
Some parts may be shown for clarity of instructions only.  
Do not proceed until you are sure all parts are present.  
Please read all instructions before proceeding.**

**IF IN ANY DOUBT WHEN FITTING OUR PRODUCTS, CONSULT ONE OF OUR DEALERS OR  
HAVE FITTED BY A QUALIFIED TECHNICIAN.**

Please note that the way the kit is packed does not necessarily represent the way of mounting to the bike.

In the event of rubber washers being used to hold components onto bolts, these rubber washers can be thrown away.

**DIGITAL COPIES OF THESE INSTRUCTIONS ARE AVAILABLE FROM  
[WWW.RG-RACING.COM](http://WWW.RG-RACING.COM)**



<b>LEGEND</b>		
<b>ITEM No.</b>	<b>DESCRIPTION</b>	<b>QTY</b>
ITEM 1	TB0360 PART 1 – TAIL BRACKET	1
ITEM 2	TB0360 PART 2 – BRACKET SPACER	1
ITEM 3	LA0002 – LICENCE PLATE ILLUMINATOR	1
ITEM 4	M6x30MM BUTTON HEAD BOLT	4
ITEM 5	M6 WASHER	8
ITEM 6	M6 NYLOC NUT	4
ITEM 7	HEAT SHRINK	1
ITEM 8	LICENCE PLATE LIGHT CONNECTOR – CON0051 (2020 ONWARDS)	1
ITEM 9	LICENCE PLATE LIGHT CONNECTOR – CON0007 (PRE 2020 BIKES)	1
ITEM 10	CABLE TIES	4
ITEM 11	REFLECTOR	1

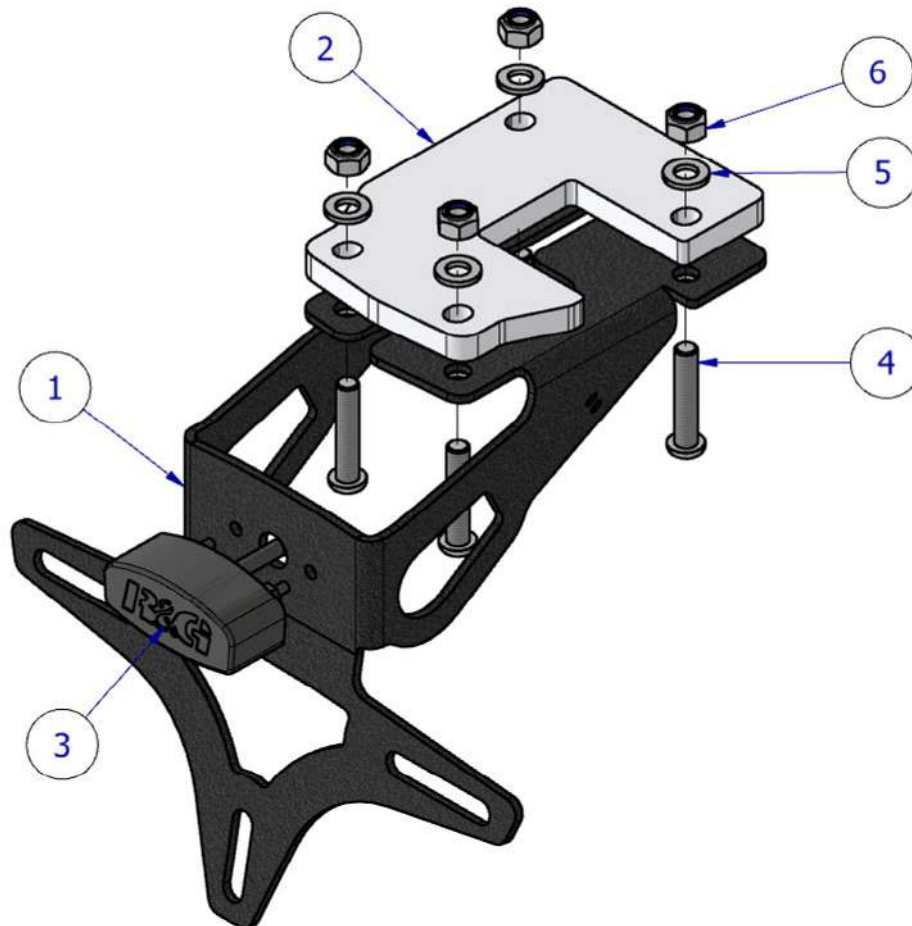

R&amp;G

Unit 1, Shelley's Lane, East Worldham, Alton, Hampshire, GU34 3AQ

Tel: +44 (0)1420 89007 Fax: +44 (0)1420 87301 [www.rg-racing.com](http://www.rg-racing.com) Email: [info@rg-racing.com](mailto:info@rg-racing.com)



**TOOLS REQUIRED**

- T25 Torx tool
- 6mm + 10mm sockets or spanners
- Small amount of superglue or similar adhesive
  - Electrical wire crimps
- Small flat bladed screw driver
- Loctite or similar thread locker

**GENERAL TORQUE SETTINGS**

- M4 BOLT = 8Nm
- M5 BOLT = 12Nm
- M6 BOLT = 15Nm
- M8 BOLT = 20Nm
- M10 BOLT = 40Nm
- M12 BOLT = 40Nm



**Picture 1**



**Picture 2**

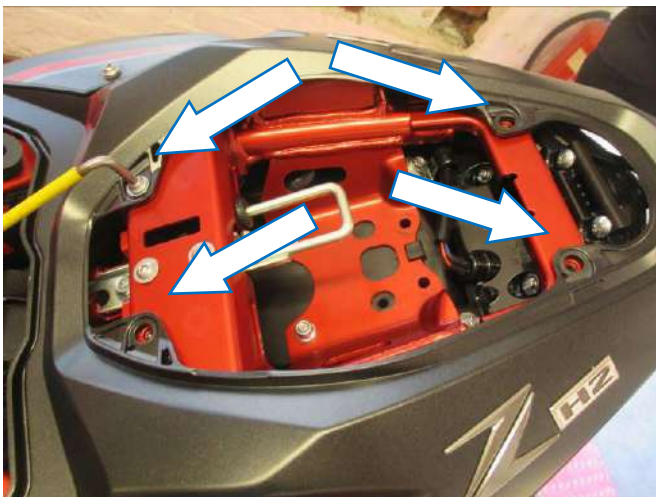

**Picture 3**

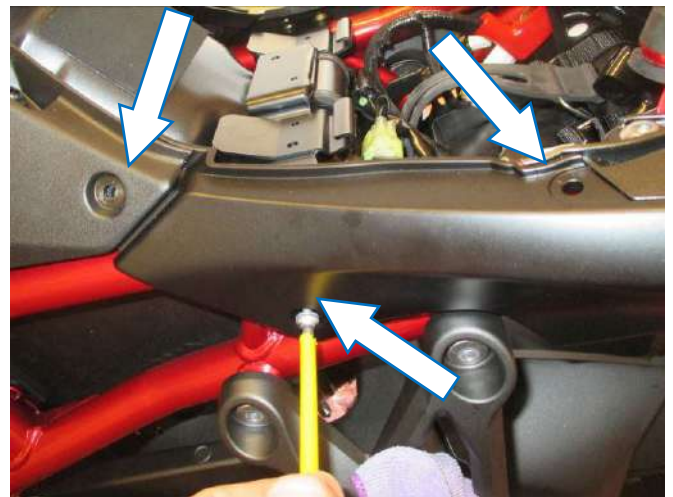

**Picture 4**

R&G

Unit 1, Shelley's Lane, East Worldham, Alton, Hampshire, GU34 3AQ

Tel: +44 (0)1420 89007 Fax: +44 (0)1420 87301 [www.rg-racing.com](http://www.rg-racing.com) Email: [info@rg-racing.com](mailto:info@rg-racing.com)



**Picture 5**



**Picture 6**

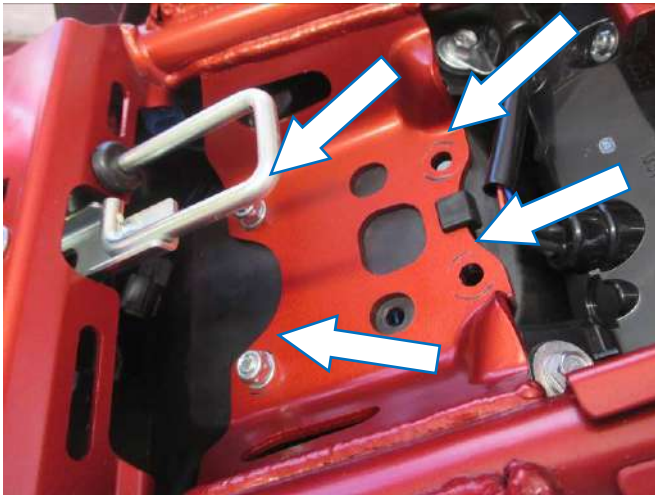

**Picture 7**



**Picture 8**



**Picture 9**



**Picture 10**



**Picture 11**



**Picture 12**



**Picture 13**



**Picture 14**



**Picture 15**



**Picture 16**



**Picture 17**



**Picture 18**



**Picture 19**



**Picture 20**



**Picture 21**



**Picture 22**



## FITTING INSTRUCTIONS

- To fit the R&G tail tidy, first remove the pillion seat using the key as shown in **picture 1**.
- Slide the rider's seat catch as shown in **picture 2** and remove the rider seat.
- Remove the four bolts arrowed in **picture 3**.
- Remove the five bolts arrowed in **pictures 4 and 5**, then remove the side panel/cover as shown in **picture 6**.
- Repeat the above for the opposite side.
- Remove the four bolts arrowed in **picture 7**, then carefully unclip and remove the rear seat cowl as shown in **picture 8**.



- Disconnect the three wiring plug sockets for the licence plate illuminator and indicators arrowed in **picture above**.
- Carefully lower the original licence plate bracket while feeding the wiring through the hole in the under-tray as shown in **picture 9** and remove.
- Depending on the bike You may need to further disassemble & slide the undertray towards the rear of the bike to allow the connectors to pass through the hole in the undertray.
- Remove the reflector bracket nut arrowed in **picture 10**.
- Remove the two screws arrowed in **pictures 11 and 12**, this will allow the bracket to be split apart as shown in **picture 13**.
- Remove the screw arrowed in **picture 14**.
- Remove the indicator clamp bracket as shown in **picture 15**.
- Remove the indicator spreader plate as shown in **picture 16**.
- Gently squeeze the indicator stem and remove the indicator.
- Repeat the above steps to remove the opposite indicator.
- Fit the indicators into the new licence plate bracket (**item 1**) and secure as shown in **pictures 17, 18**.
- Fit the LA0002 Licence plate illuminator (**item 3**) to the tail bracket using the M4 nuts provided as shown in pictures **19 & 20**
- Following the Assembly diagram, assemble the tail tidy Bracket & spacer and offer into position on the under-tray while feeding the wiring through the slot in the under-tray as shown in **picture 21** and secure using the four nuts with washers (**items 5 and 6**) as shown in **picture 22**. Ensure the wires are not crushed when tightening.
- Select the correct Licence plate connector for the bike (**item 8 or 9**) Route the wiring as original and reconnect the licence plate illuminator using the supplied connector to the original plug socket.

R&G

Unit 1, Shelley's Lane, East Worldham, Alton, Hampshire, GU34 3AQ

Tel: +44 (0)1420 89007 Fax: +44 (0)1420 87301 [www.rg-racing.com](http://www.rg-racing.com) Email: [info@rg-racing.com](mailto:info@rg-racing.com)



- Once licence plate is fixed and wires are correctly routed, use the cable ties (item 10) provided to secure the wiring to the tail tidy using the slots in the bracket.
- Refit and secure the rear seat cowl and side panels/covers as original.
- Refit the rider and pillion seats as original and licence plate (it may require drilling).

**IMPORTANT: –DEPENDING ON THE SIZE AND ORIENTATION OF THE LICENCE PLATE, BEFORE DRILLING CHECK THAT THE LICENCE PLATE DOES NOT OBSCURE THE INDICATORS FROM THE REAR OF THE BIKE.**

- Depending on local laws, fit the reflector provided (item 12) to an appropriate location.

**IMPORTANT: FOR SAFETY, ENSURE THE LICENCE PLATE IS PLACED AS HIGH AS POSSIBLE ON THE TAIL TIDY (IT MAY REQUIRE DRILLING). IF FITTING A LICENCE PLATE OF 200MM OR LONGER (INCLUDING ANY SHROUD OR REFLECTOR ATTACHMENT) TO THE BRACKET, BEFORE RIDING, FULLY COMPRESS THE SUSPENSION TO ENSURE NO PART OF THE ASSEMBLY CAN CONTACT THE TYRE WHILE THE VEHICLE IS IN MOTION OR UNDER LOAD. IT IS YOUR RESPONSIBILITY TO CHECK FOR THIS POSSIBILITY AND TAKE AVOIDING ACTION. FAILURE TO CHECK THIS COULD RESULT IN SERIOUS INJURY OR DAMAGE TO THE MOTORCYCLE.**

- You can now re-fit the pillion seat/ cowl.
- At this stage, test all light functionality including the licence plate illuminator before riding.

**See more R&G products for your Motorcycle in the links below:**

[R&G Racing | All Products for Kawasaki - ZH2 \(2020\) \(rg-racing.com\)](http://rg-racing.com)

ISSUE 1 14/04/2023 (DM)

#### **CONSUMER NOTICE**

The catalogue description and any exhibition of samples are only broad indications of the Products and R&G may make design changes which do not diminish their performance or visual appeal and supplying them in such state shall conform to the order. The Buyer acknowledges no representation or warranty (other than as to title) has been given or will apply to the Products other than those in R&G's order or confirmation and the Buyer confirms it has chosen the Products as being of merchantable quality and suitable for its particular purposes. Where R&G fits the Products or undertakes other services it shall exercise reasonable skill and care and rectify any fault free of charge unless the workmanship has been disturbed. The Buyer is responsible for ensuring that the warranty on the motorcycle is not affected by the fitting of the Products. On return of any defective Products R&G shall at its option either supply a replacement or refund the purchase money but shall not be liable if the Products have been modified or used or maintained otherwise than in accordance with R&G's or manufacturer's instructions and good engineering practice or if the defect arises from accident or neglect. Other than identified above and subject to R&G not limiting its liability for causing death and personal injury, it shall not be liable for indirect or consequential loss and otherwise its liability shall be limited to the amounts paid by the Buyer for the Products or the fitting or service concerned. These terms do not affect the Buyer's statutory rights.

#### **R&G RETURNS POLICY (NON-FAULTY GOODS)**

Returns must be pre-authorized (if not pre-authorized the return will be rejected). Goods may only be returned direct to us if they were purchased direct from us (customer must prove if necessary). Otherwise to be returned to original vendor. Goods must be in re-sellable condition, in the opinion of R&G. All returns are subject to a 25% restocking and handling fee (25% of the gross value exc. P&P – at the prevailing price at time of purchase). The customer must pay any and all carriage charges. No returns of discontinued products, unless within 14 days of purchase. This policy does not affect your statutory rights and does not refer to faulty goods.

R&G

Unit 1, Shelley's Lane, East Worldham, Alton, Hampshire, GU34 3AQ

Tel: +44 (0)1420 89007 Fax: +44 (0)1420 87301 [www.rg-racing.com](http://www.rg-racing.com) Email: [info@rg-racing.com](mailto:info@rg-racing.com)





## **MONTAGEANLEITUNG FÜR LP0360 KENNZEICHENHALTER**



**Alle Kit-Teile sind auf den nachfolgenden Seiten abgebildet und gekennzeichnet.**

**Die abgebildeten Teile dienen lediglich zur Erklärung.**

**Überprüfen Sie zuerst, dass alle Teile vorhanden sind.**

**Lesen Sie die Montageanleitung komplett durch, bevor Sie anfangen.**

**WENN SIE BEI DER MONTAGE DIESES PRODUKTES UNSICHER SIND, BITTE EINEN  
UNSERER HÄNDLER KONTAKTIEREN ODER DAS KIT VON EINEM QUALIFIZIERTEN  
ZWEIRAD-MECHANIKER MONTIEREN LASSEN.**

Die Verpackung der Teile stellt nicht die Reihenfolge der Montage dar.

Hinweis für Kits mit Plastikunterlegscheiben an den Schrauben –  
Diese Plastik-Unterlegscheiben werden nicht für den Einbau benötigt

**EINE DIGITALE VERSION DIESER MONTAGEANLEITUNG KANN AUF FOLGENDER  
SEITE HERUNTERGELADEN WERDEN:**

**[WWW.RG-RACING.COM](http://WWW.RG-RACING.COM)**

R&G

Unit 1, Shelley's Lane, East Worldham, Alton, Hampshire, GU34 3AQ

Tel: +44 (0)1420 89007 Fax: +44 (0)1420 87301 [www.rg-racing.com](http://www.rg-racing.com) Email: [info@rg-racing.com](mailto:info@rg-racing.com)



<b>LIEFERUMFANG</b>		
<b>ARTIKEL NR.</b>	<b>BESCHREIBUNG</b>	<b>MENGE</b>
ARTIKEL 1	TB0360 TEIL 1 - KENNZEICHENHALTER	1
ARTIKEL 2	TB0360 TEIL 2 - DISTANZHALTER KENNZEICHENHALTER	1
ARTIKEL 3	LA0002 - KENNZEICHENBELEUCHTUNG	1
ARTIKEL 4	M6x30MM INBUSSCHRAUBE	4
ARTIKEL 5	M6 UNTERLEGSCHIEBE	6
ARTIKEL 6	M6 SELBSTSICHERNDE MUTTER	1
ARTIKEL 7	SCHRUMPFSCHLAUCH	1
ARTIKEL 8	VERBINDUNG KENNZEICHENBELEUCHTUNG - CON0051 (Ab Baujahr 2020)	2
ARTIKEL 9	VERBINDUNG KENNZEICHENBELEUCHTUNG CON0007 (bis Baujahr 2020)	2
ARTIKEL 10	KABELBINDER	2
ARTIKEL 11	RÜCKSTRAHLER	4

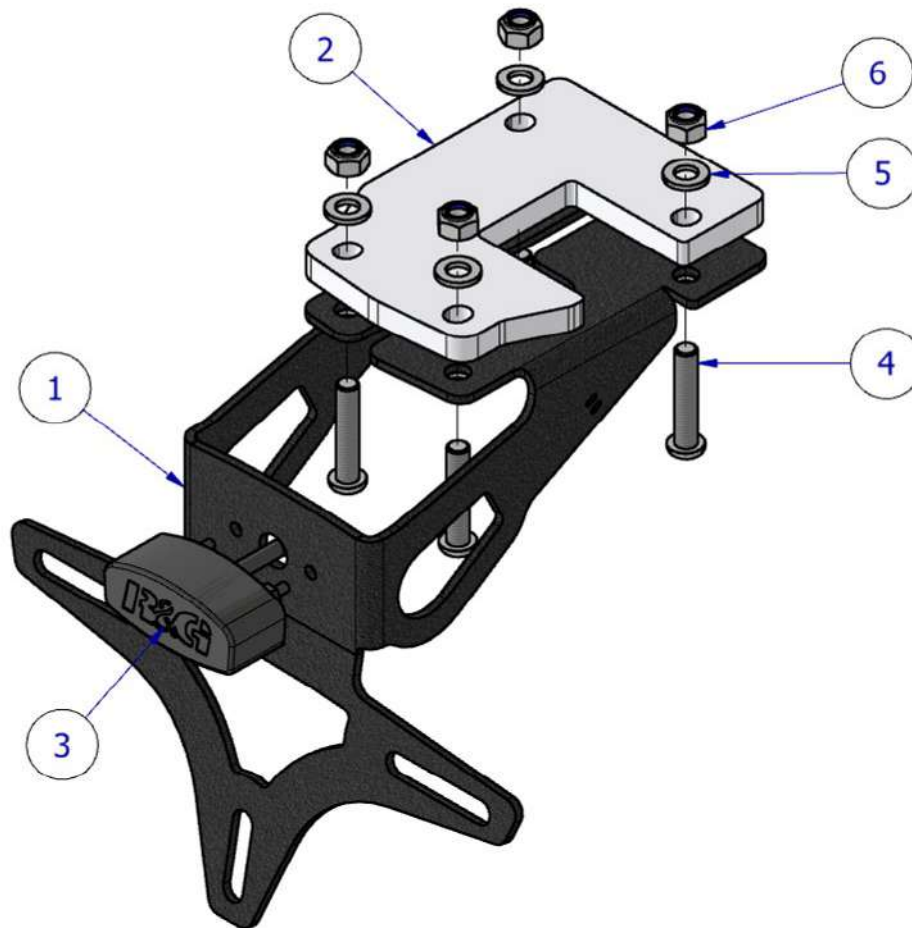

R&amp;G

Unit 1, Shelley's Lane, East Worldham, Alton, Hampshire, GU34 3AQ

Tel: +44 (0)1420 89007 Fax: +44 (0)1420 87301 [www.rg-racing.com](http://www.rg-racing.com) Email: [info@rg-racing.com](mailto:info@rg-racing.com)

**SIE BENÖTIGEN FOLGENDES WERKZEUG**

- 6mm + 10mm Steckschlüssel oder Schraubenschlüssel
- Kleine Menge Sekundenkleber oder ähnlicher Klebstoff
- ElektRoniker-Zange / Crimps
- Kl. Flachklingen-Schraubenzieher
  - Loctite oder eine ähnliche Schraubensicherung

**ALLGEM. ANZUGSDREHMOMENT**

M4 SCHRAUBE = 8Nm  
 M5 SCHRAUBE = 12Nm  
 M6 SCHRAUBE = 15Nm  
 M8 SCHRAUBE = 20Nm  
 M10 SCHRAUBE = 40Nm  
 M12 SCHRAUBE = 40Nm



Abbildung 1



Abbildung 2



Abbildung 3



Abbildung 4

R&amp;G

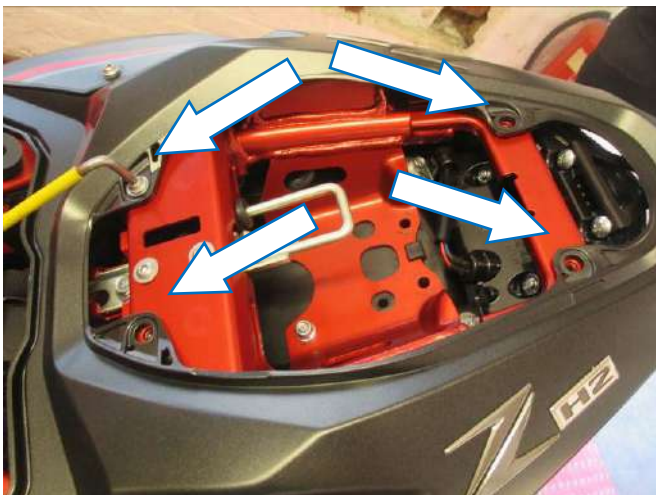
Unit 1, Shelley's Lane, East Worldham, Alton, Hampshire, GU34 3AQ

Tel: +44 (0)1420 89007 Fax: +44 (0)1420 87301 [www.rg-racing.com](http://www.rg-racing.com) Email: [info@rg-racing.com](mailto:info@rg-racing.com)



**Abbildung 5**



**Abbildung 6**

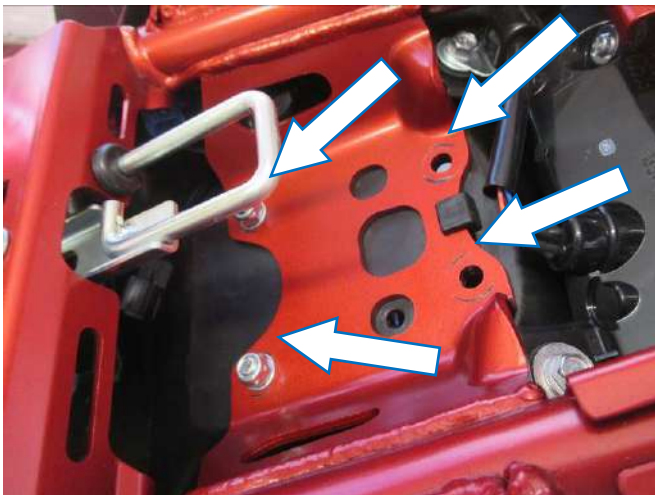

**Abbildung 7**



**Abbildung 8**



**Abbildung 9**



**Abbildung 10**



**Abbildung 11**



**Abbildung 12**



**Abbildung 13**



**Abbildung 14**



**Abbildung 15**



**Abbildung 16**



**Abbildung 17**



**Abbildung 18**



**Abbildung 19**



**Abbildung 20**



**Abbildung 21**



**Abbildung 22**



## MONTAGEANLEITUNG

- Um den R&G Kennzeichenhalter zu montieren, entfernen Sie zuerst den Beifahrersitz mit dem Schlüssel wie in **Abbildung 1** abgebildet.
- Schieben Sie die Sitzverriegelung wie in **Abbildung 2** und entfernen Sie den Fahrersitz.
- Entfernen Sie die vier Schrauben, die in **Abbildung 3** gekennzeichnet sind.
- Entfernen Sie die fünf Schrauben, die in den **Abbildungen 4 und 5** gekennzeichnet sind, dann entfernen Sie die Seitenverkleidung/Abdeckung wie in **Abbildung 6** abgebildet.
- An der gegenüberliegenden Seite wiederholen.
- Entfernen Sie die vier Schrauben, die in **Abbildung 7** gekennzeichnet sind, dann lösen und entfernen Sie die hintere Sitzabdeckung wie in **Abbildung 8** abgebildet.

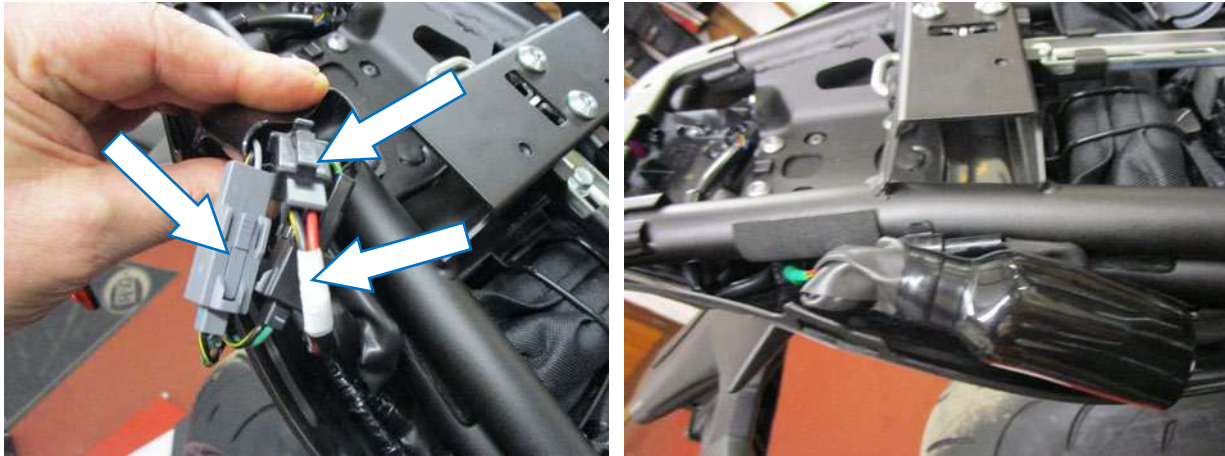

- Trennen Sie die drei Steckverbindungen für die Kennzeichenbeleuchtung und die Blinker, die in der **Abbildung oben** mit Pfeilen gekennzeichnet sind.
- Den original Kennzeichenhalter vorsichtig herabsetzen und die Kabel durch die Öffnung in der unteren Abdeckung führen wie in **Abbildung 9** abgebildet und anschließend entfernen.
- Abhängig vom Modelltyp muss die untere Abdeckung weiter abgebaut werden und nach hinten verschieben, sodass die Verbinder durch die Öffnung in der unteren Abdeckung passen.
- Entfernen Sie die Mutter für den Rückstrahler, die in **Abbildung 10** abgebildet ist.
- Entfernen Sie die zwei Schrauben, die in den **Abbildungen 11 und 12** abgebildet sind, sodass der Kennzeichenhalter in zwei Teilen getrennt werden kann wie in **Abbildung 13** abgebildet.
- Entfernen Sie die Schraube, die in **Abbildung 14** markiert ist.
- Entfernen Sie die Klemmhalterung für den Blinker wie in **Abbildung 15** abgebildet.
- Entfernen Sie die Distanzplatte für den Blinker wie in **Abbildung 16** abgebildet.
- Den Stiel vorsichtig zusammendrücken und den Blinker entfernen
- Wiederholen Sie die Schritte oben, um den zweiten Blinker zu entfernen.
- Montieren Sie die Blinker am neuen Kennzeichenhalter (**Artikel 1**) und befestigen Sie sie wie in den **Abbildungen 17 und 18** abgebildet.
- Montieren Sie die LA0002 Kennzeichenbeleuchtung (**Artikel 3**) an Kennzeichenhalter mit den M4 Muttern von Kit wie in den **Abbildungen 19 & 20** abgebildet.
- Entsprechend der Zeichnung Zusammenbau, die Kennzeichenhalter und Distanzhalter zusammenbauen und in Position an der unteren Abdeckung bringen. Die Kabel durch die Öffnung in der unteren Abdeckung schieben wie in **Abbildung 21** abgebildet und mit den vier Muttern und Unterlegscheiben (**Artikel 5 und 6**) sichern wie in **Abbildung 22** abgebildet. Achten Sie darauf, dass die Kabel beim Befestigen nicht eingeklemmt oder zerquetscht werden.

R&G

Unit 1, Shelley's Lane, East Worldham, Alton, Hampshire, GU34 3AQ

Tel: +44 (0)1420 89007 Fax: +44 (0)1420 87301 [www.rg-racing.com](http://www.rg-racing.com) Email: [info@rg-racing.com](mailto:info@rg-racing.com)



- Wählen Sie den richtigen Kennzeichen-Verbinder für das Motorrad (**Artikel 8 oder 9**). Die Verkabelung wie ursprünglich verlegen und die Kennzeichenbeleuchtung wieder verbinden mittels des mitgelieferten Verbinders und original Steckverbinder.
- Sobald der Kennzeichenhalter fixiert ist und die Kabel ordentlich verlegt sind, benutzen Sie die Kabelbinder vom Kit (**Artikel 10**), um die Kabel am Kennzeichenhalter zu sichern (benutzen Sie die Schlitze im Kennzeichenhalter).
- Montieren Sie die hintere Sitzabdeckung und Seitenteile/Abdeckungen wie ursprünglich wieder.
- Montieren Sie die Fahrer- und Beifahrersitze und den Kennzeichenhalter (Bohrungen im Kennzeichen evtl. notwendig) wie ursprünglich wieder.

**WICHTIG: ABHÄNGIG VON DER GRÖSSE UND ORIENTIERUNG DES KENNZEICHENS, BEVOR SIE ANFANGEN ZU BOHREN, ÜBERPRÜFEN SIE, DASS DER KENNZEICHENHALTER DIE BLINKER HINTEN AM MOTORRAD NICHT VERDECKT.**

- Entsprechend der gesetzlichen Vorschriften, den mitgelieferten Rückstrahler (**Artikel 12**) an die dafür vorgesehene Stelle anbringen.

**WICHTIG: AUS SICHERHEITSGRÜNDEN STELLEN SIE SICHER, DASS DAS KENNZEICHEN SO HOCH WIE MÖGLICH AM KENNZEICHENHALTER ANGEBRACHT WIRD (Bohrungen im Kennzeichen evtl. notwendig). WENN SIE EIN KENNZEICHEN MIT 200 MM ODER GRÖßER (INKL. ABDECKUNG ODER RÜCKSTRAHLER) MONTIEREN, DAS MOTORRAD KOMPLETT EINFEDERN, UM SICHERZUSTELLEN, DASS KEINE TEILE DAS HINTERRAD BERÜHREN KÖNNEN, WENN DAS MOTORRAD IN BEWEGUNG ODER UNTER SCHWERER LAST IST. ES LIEGT IN IHRER VERANTWORTUNG DIES ZU ÜBERPRÜFEN UND, WENN NOTWENDIG, DIE ENTSPRECHENDEN SCHRITTE VORZUNEHMEN. DIE NICHTBEACHTUNG DIESES SICHERHEITSHINWEISES KANN ZU SCHWEREN VERLETZUNGEN FÜHREN.**

- Sie können jetzt den Beifahrersitz / die Abdeckung wieder montieren.
- Überprüfen Sie die Funktion der kompletten Beleuchtung (Blinker und Kennzeichenhalter) vor Gebrauch des Fahrzeuges

**Klicken Sie hier, um weitere R&G Produkte für Ihr Motorrad zu finden:**

[R&G Racing | All Products for Kawasaki - ZH2 \(2020\) \(rg-racing.com\)](http://www.rg-racing.com)

AUSGABE 1 14/04/2023 (DM)

#### CONSUMER NOTICE

The catalogue description and any exhibition of samples are only broad indications of the Products and R&G may make design changes which do not diminish their performance or visual appeal and supplying them in such state shall conform to the order. The Buyer acknowledges no representation or warranty (other than as to title) has been given or will apply to the Products other than those in R&G's order or confirmation and the Buyer confirms it has chosen the Products as being of merchantable quality and suitable for its particular purposes. Where R&G fits the Products or undertakes other services it shall exercise reasonable skill and care and rectify any fault free of charge unless the workmanship has been disturbed. The Buyer is responsible for ensuring that the warranty on the motorcycle is not affected by the fitting of the Products. On return of any defective Products R&G shall at its option either supply a replacement or refund the purchase money but shall not be liable if the Products have been modified or used or maintained otherwise than in accordance with R&G's or manufacturer's instructions and good engineering practice or if the defect arises from accident or neglect. Other than identified above and subject to R&G not limiting its liability for causing death and personal injury, it shall not be liable for indirect or consequential loss and otherwise its liability shall be limited to the amounts paid by the Buyer for the Products or the fitting or service concerned. These terms do not affect the Buyer's statutory rights.

R&G

Unit 1, Shelley's Lane, East Worldham, Alton, Hampshire, GU34 3AQ

Tel: +44 (0)1420 89007 Fax: +44 (0)1420 87301 [www.rg-racing.com](http://www.rg-racing.com) Email: [info@rg-racing.com](mailto:info@rg-racing.com)



**R&G RETURNS POLICY (NON-FAULTY GOODS)**

Returns must be pre-authorized (if not pre-authorized the return will be rejected). Goods may only be returned direct to us if they were purchased direct from us (customer must prove if necessary). Otherwise to be returned to original vendor. Goods must be in re-sellable condition, in the opinion of R&G. All returns are subject to a 25% restocking and handling fee (25% of the gross value exc. P&P – at the prevailing price at time of purchase). The customer must pay any and all carriage charges. No returns of discontinued products, unless within 14 days of purchase. This policy does not affect your statutory rights and does not refer to faulty goods.

R&amp;G

Unit 1, Shelley's Lane, East Worldham, Alton, Hampshire, GU34 3AQ  
Tel: +44 (0)1420 89007 Fax: +44 (0)1420 87301 [www.rg-racing.com](http://www.rg-racing.com) Email: [info@rg-racing.com](mailto:info@rg-racing.com)



## **NOTICE DE MONTAGE POUR LP0360 SUPPORT DE PLAQUE**



**CE KIT CONTIENT LES ARTICLES ILLUSTRÉS ET ÉTIQUETES SUR LA PAGE.**

CERTAINES PARTIES PEUVENT ÊTRE PRÉSENTES UNIQUEMENT POUR LA CLARTÉ DES INSTRUCTIONS.

NE PAS PROCÉDER AU MONTAGE TANT QUE VOUS N'ÊTES PAS SÛR QUE TOUTES LES PIÈCES SOIENT PRÉSENTES.

**VEUILLEZ LIRE TOUTES LES INSTRUCTIONS AVANT DE CONTINUER.**

**EN CAS DE DOUTE LORS DU MONTAGE DE NOS PRODUITS, CONSULTEZ UN DE NOS  
REVENDEURS OU FAITES APPEL À UN TECHNICIEN QUALIFIÉ.**

VEUILLEZ NOTER QUE LA FAÇON DONT LE KIT EST EMBALLÉ NE REPRÉSENTE PAS NECESSAIREMENT LA  
MANIÈRE DE LE MONTER SUR LA MOTO.

SI DES RONDELLES EN CAOUTCHOUC SONT UTILISÉES POUR MAINTENIR LES COMPOSANTS SUR LES  
BOULONS, ELLES PEUVENT ÊTRE JETÉES.

**NOTICE DISPONIBLE AU TÉLÉCHARGEMENT SUR : [WWW.RG-RACING.COM](http://WWW.RG-RACING.COM)**

R&G

Unit 1, Shelley's Lane, East Worldham, Alton, Hampshire, GU34 3AQ  
Tel: +44 (0)1420 89007 Fax: +44 (0)1420 87301 [www.rg-racing.com](http://www.rg-racing.com) Email: [info@rg-racing.com](mailto:info@rg-racing.com)



<b>LEGENDE</b>		
<b>ARTICLE No.</b>	<b>DESCRIPTION</b>	<b>QTÉ</b>
ARTICLE 1	TB0360 PART 1 – SUPPORT DE PLAQUE	1
ARTICLE 2	TB0360 PART 2 – ENTRETOISE DE SUPPORT	1
ARTICLE 3	LA0002 – FEU DE PLAQUE	1
ARTICLE 4	M6x30MM BOULON	4
ARTICLE 5	M6 RONDELLE	6
ARTICLE 6	M6 ÉCROU	1
ARTICLE 7	MANCHON THERMO RÉTRACTABLE	1
ARTICLE 8	CONNECTEUR DE FEU DE PLAQUE- CON0051 (2020 VERS L'AVANT)	2
ARTICLE 9	CONNECTEUR DE FEU DE PLAQUE – CON0007 (PRE 2020 BIKES)	2
ARTICLE 10	COLLIERS DE SERRAGE	2
ARTICLE 11	RÉFLECTEUR	4

R&amp;G

Unit 1, Shelley's Lane, East Worldham, Alton, Hampshire, GU34 3AQ

Tel: +44 (0)1420 89007 Fax: +44 (0)1420 87301 [www.rg-racing.com](http://www.rg-racing.com) Email: [info@rg-racing.com](mailto:info@rg-racing.com)

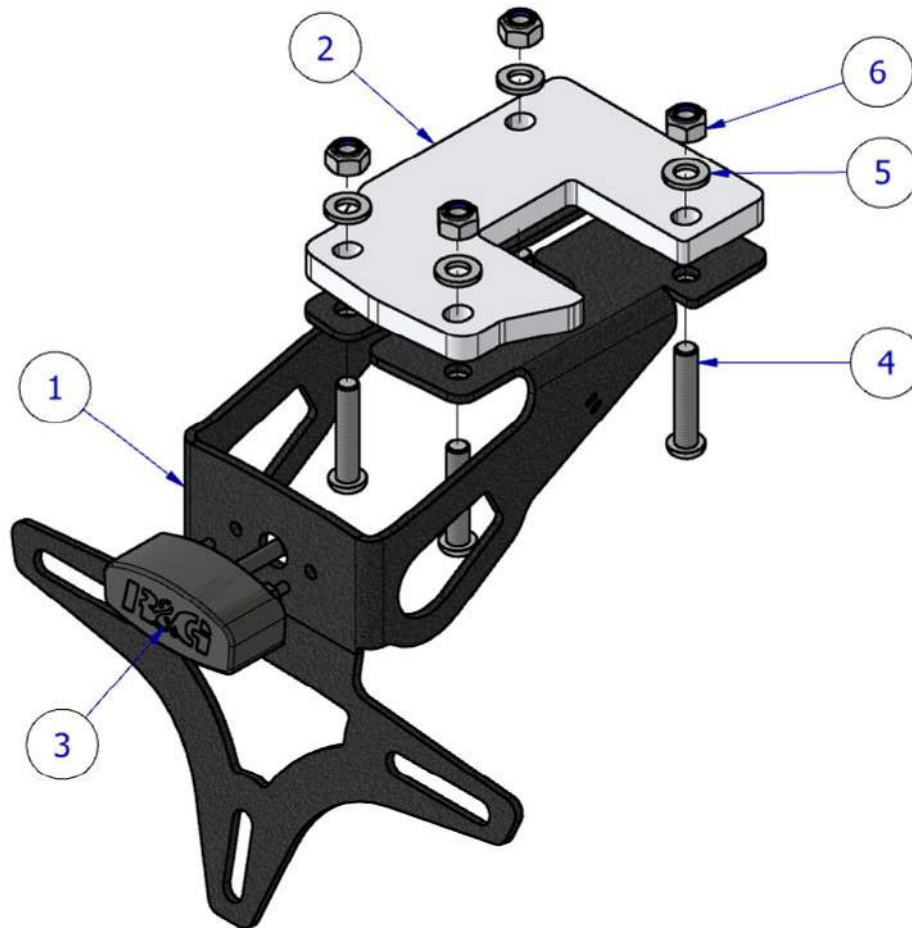

### OUTILS REQUIS

- Clé Torx T25
- Clé à cliquet + douilles 6mm + 10mm ou clé à molette
- Un peu de superglue ou adhésif similaire
  - Pincés électriques
  - Petit tournevis plat
- Colle Loctite ou frein filet similaire

### VALEURS DE SERRAGE

- M4 BOULON = 8Nm
- M5 BOULON = 12Nm
- M6 BOULON = 15Nm
- M8 BOULON = 20Nm
- M10 BOULON = 40Nm
- M12 BOULON = 40Nm

R&G

Unit 1, Shelley's Lane, East Worldham, Alton, Hampshire, GU34 3AQ  
 Tel: +44 (0)1420 89007 Fax: +44 (0)1420 87301 [www.rg-racing.com](http://www.rg-racing.com) Email: [info@rg-racing.com](mailto:info@rg-racing.com)



**Photo 1**



**Photo 2**

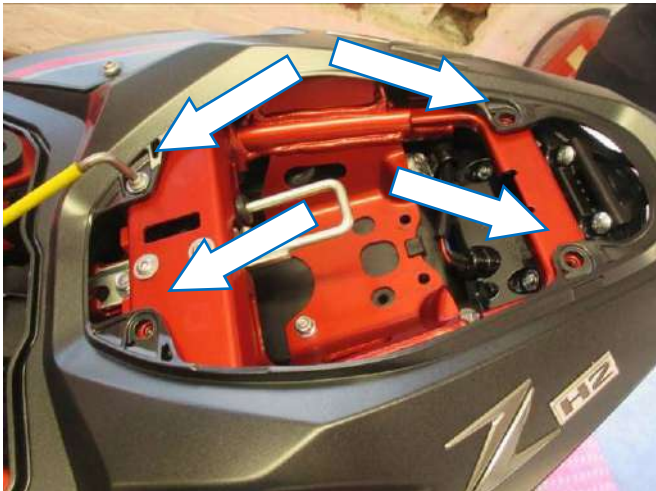

**Photo 3**

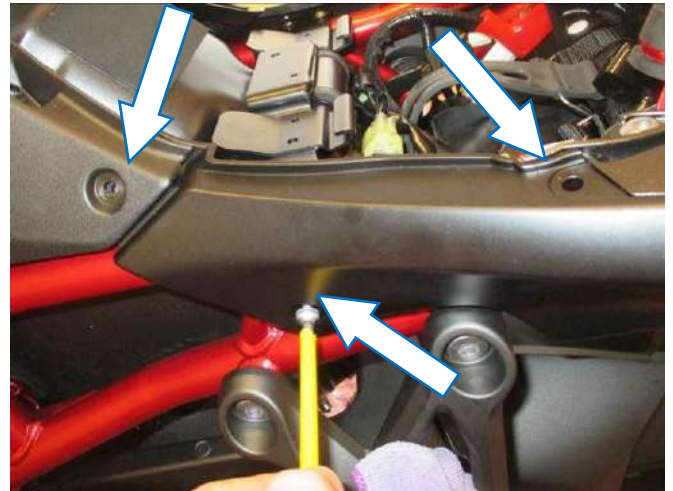

**Photo 4**

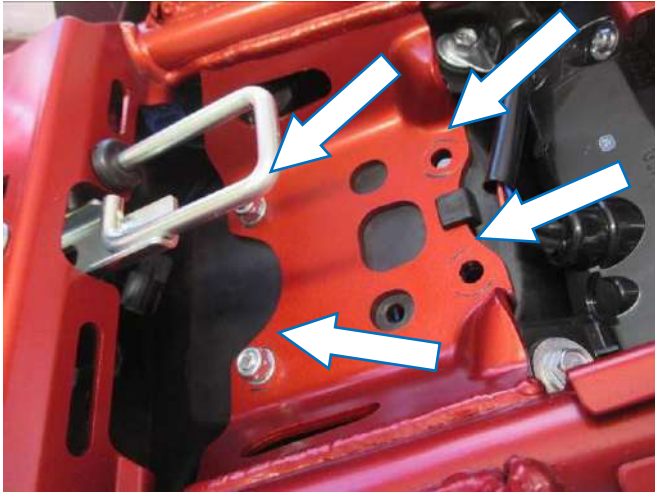

**Photo 5**



**Photo 6**

R&G



**Photo 7**



**Photo 8**



**Photo 9**



**Photo 10**



**Photo 11**



**Photo 12**



**Photo 13**



**Photo 14**



**Photo 15**



**Photo 16**



**Photo 17**



**Photo 18**



Photo 19

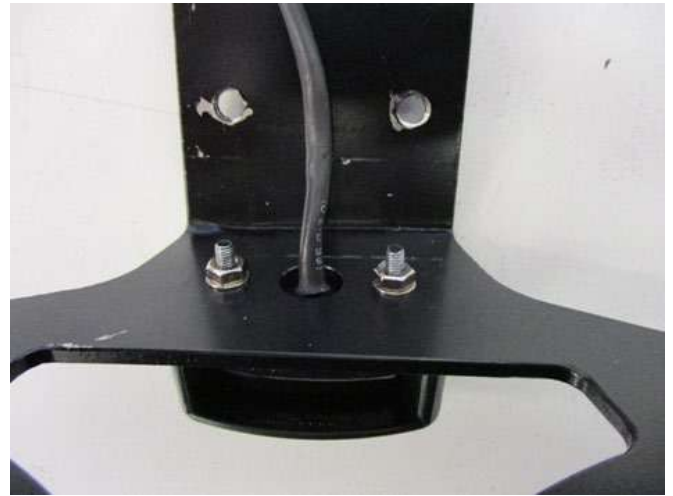

Photo 20



Photo 21



Photo 22

### **NOTICE DE MONTAGE**

- Pour monter le support arrière R&G, retirez d'abord la selle passager à l'aide de la clé comme indiqué sur la photo 1.
- Faites glisser le loquet de la selle du pilote comme indiqué sur la photo 2 et retirez la selle du pilote.
- Retirez les quatre boulons fléchés sur la photo 3.
- Retirez les cinq boulons fléchés sur les photos 4 et 5, puis retirez le panneau latéral/couvercle comme indiqué sur la photo 6.
- Répétez ce qui précède du côté opposé.
- Déposer les quatre vis fléchées sur la photo 7, puis déclipser et retirer délicatement le capot de siège arrière comme indiqué sur la photo 8.

R&amp;G

Unit 1, Shelley's Lane, East Worldham, Alton, Hampshire, GU34 3AQ

Tel: +44 (0)1420 89007 Fax: +44 (0)1420 87301 [www.rg-racing.com](http://www.rg-racing.com) Email: [info@rg-racing.com](mailto:info@rg-racing.com)



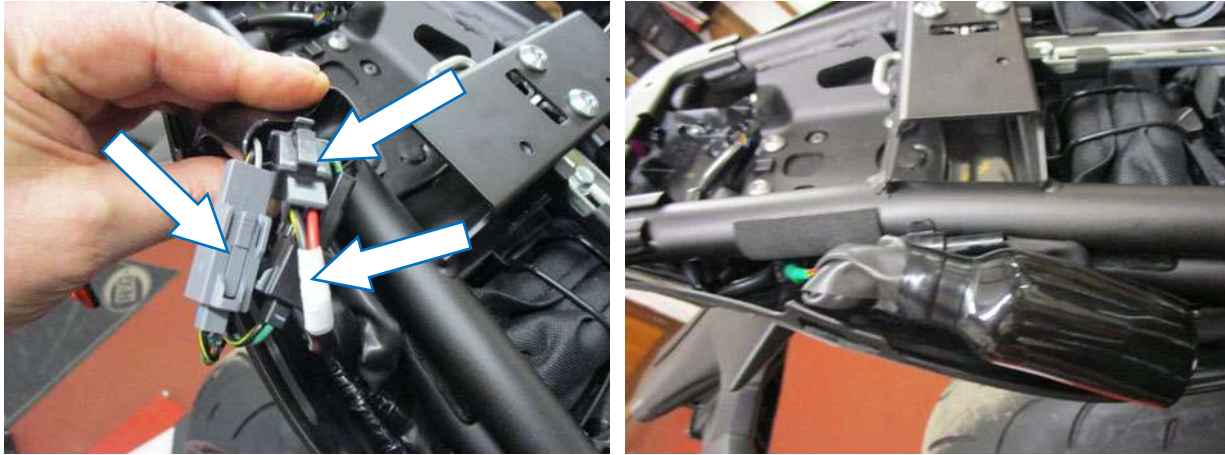

- Débranchez les trois douilles de câblage pour l'éclairage de la plaque d'immatriculation et les clignotants fléchés sur la photo ci-dessus.
- Abaissez délicatement le support de plaque d'immatriculation d'origine tout en faisant passer le câblage par le trou du sous-plateau comme indiqué sur la photo 9 et retirez-le.
- En fonction de la moto, vous devrez peut-être démonter davantage et faire glisser le passage de roue vers l'arrière de la moto pour permettre aux connecteurs de passer à travers le trou du passage de roue.
- Retirez l'écrou du support du réflecteur fléché sur la photo 10.
- Retirez les deux vis fléchées sur les photos 11 et 12, cela permettra de séparer le support comme indiqué sur la photo 13.
- Retirez la vis fléchée sur la photo 14.
- Retirez le support de fixation de clignotant comme indiqué sur la photo 15.
- Retirez la plaque de répartition de clignotant comme indiqué sur la photo 16.
- Appuyez doucement sur la tige de clignotant et retirez le clignotant.
- Répétez les étapes ci-dessus pour supprimer le clignotant opposé.
- Montez les clignotants sur le nouveau support de plaque d'immatriculation (article 1) et fixez comme indiqué sur les photos 17, 18.
- Montez l'éclairage de plaque d'immatriculation LA0002 (article 3) sur le support à l'aide des écrous M4 fournis comme indiqué sur les photos 19 et 20.
- En suivant le schéma de montage, assemblez le support de rangement arrière et l'entretoise et présentez le en position sur le sous-plateau tout en faisant passer le câblage à travers la fente dans le sous-plateau comme indiqué sur la photo 21 et fixez à l'aide des quatre écrous avec
- rondelles (articles 5 et 6) comme indiqué sur la photo 22. Assurez-vous que les fils ne sont pas écrasés lors du serrage.
- Sélectionnez le bon connecteur de plaque d'immatriculation à la moto (article 8 ou 9) et acheminez le câblage comme d'origine et reconnectez l'éclairage de plaque d'immatriculation à la prise de courant d'origine à l'aide du connecteur fourni
- Une fois la plaque d'immatriculation fixée et les fils correctement acheminés, utilisez les serre-câbles (article 10) fournis pour fixer le câblage au rangement arrière à l'aide des fentes du support.
- Remontez et fixez le capot de siège arrière et les panneaux/couvercles latéraux comme d'origine.
- Remonter les selles pilote et passager comme d'origine et plaque d'immatriculation (cela peut nécessiter un perçage).

R&amp;G

Unit 1, Shelley's Lane, East Worldham, Alton, Hampshire, GU34 3AQ

Tel: +44 (0)1420 89007 Fax: +44 (0)1420 87301 [www.rg-racing.com](http://www.rg-racing.com) Email: [info@rg-racing.com](mailto:info@rg-racing.com)



**IMPORTANT : EN FONCTION DE LA TAILLE ET DE L'ORIENTATION DE LA PLAQUE D'IMMATRICULATION, AVANT LE PERÇAGE, VÉRIFIEZ QUE LA PLAQUE D'IMMATRICULATION N'OBSTRUE PAS LES CLIGNOTANTS À L'ARRIÈRE DE LA MOTO.**

- Selon les lois locales, installez le réflecteur fourni (article 12) à un endroit approprié.

**IMPORTANT: SI VOUS MONTEZ UNE PLAQUE D'IMMATRICULATION DE GRANDE TAILLE ET LA PLACEZ BIEN EN BAS SUR LE SUPPORT DE PLAQUE D'IMMATRICULATION, IL Y A UN RISQUE QUE LA PLAQUE D'IMMATRICULATION FRAPPE LA ROUE ARRIÈRE SOUS UNE CHARGE LOURDE ET SUR DE GROSSES BOSSES SUR LA ROUTE. IL EST DE VOTRE RESPONSABILITÉ DE VÉRIFIER CETTE POSSIBILITÉ ET DE PRENDRE DES MESURES POUR ÉVITER. NE PAS VÉRIFIER CELA POURRAIT ENTRAÎNER DES BLESSURES GRAVES.**

- Vous pouvez maintenant remettre en place la selle passager.
- À ce stade, testez toutes les fonctionnalités d'éclairage, y compris l'éclairage de la plaque d'immatriculation, avant de rouler.

**Voir plus de produits R&G pour votre moto via ce lien :**

[R&G Racing | All Products for Kawasaki - ZH2 \(2020\) \(rg-racing.com\)](https://www.rg-racing.com)

ISSUE 1 14/04/2023 (DM)

#### **CONSUMER NOTICE**

The catalogue description and any exhibition of samples are only broad indications of the Products and R&G may make design changes which do not diminish their performance or visual appeal and supplying them in such state shall conform to the order. The Buyer acknowledges no representation or warranty (other than as to title) has been given or will apply to the Products other than those in R&G's order or confirmation and the Buyer confirms it has chosen the Products as being of merchantable quality and suitable for its particular purposes. Where R&G fits the Products or undertakes other services it shall exercise reasonable skill and care and rectify any fault free of charge unless the workmanship has been disturbed. The Buyer is responsible for ensuring that the warranty on the motorcycle is not affected by the fitting of the Products. On return of any defective Products R&G shall at its option either supply a replacement or refund the purchase money but shall not be liable if the Products have been modified or used or maintained otherwise than in accordance with R&G's or manufacturer's instructions and good engineering practice or if the defect arises from accident or neglect. Other than identified above and subject to R&G not limiting its liability for causing death and personal injury, it shall not be liable for indirect or consequential loss and otherwise its liability shall be limited to the amounts paid by the Buyer for the Products or the fitting or service concerned. These terms do not affect the Buyer's statutory rights.

#### **R&G RETURNS POLICY (NON-FAULTY GOODS)**

Returns must be pre-authorized (if not pre-authorized the return will be rejected). Goods may only be returned direct to us if they were purchased direct from us (customer must prove if necessary). Otherwise to be returned to original vendor. Goods must be in re-sellable condition, in the opinion of R&G. All returns are subject to a 25% restocking and handling fee (25% of the gross value exc. P&P – at the prevailing price at time of purchase). The customer must pay any and all carriage charges. No returns of discontinued products, unless within 14 days of purchase. This policy does not affect your statutory rights and does not refer to faulty goods.

R&G

Unit 1, Shelley's Lane, East Worldham, Alton, Hampshire, GU34 3AQ

Tel: +44 (0)1420 89007 Fax: +44 (0)1420 87301 [www.rg-racing.com](http://www.rg-racing.com) Email: [info@rg-racing.com](mailto:info@rg-racing.com)